

# AIR VACUUM SYSTEMS

Screwdriver accessory to hold screws

---





## PRODUCTIVE SOLUTIONS

As an industrial process expert, we help you meet your challenges.

Productivity, safety, quality, industry 4.0 are themes on which we can offer you our expertise and our solutions. Whether in the field of assembly technology, machining or welding, our dedicated and specialised teams accompany your progress and recommend solutions and equipment to reach performance levels in line with your industrial strategy.



### Certified quality

From design to commissioning, DOGA guarantees the quality of this equipments and services according to ISO 9001: 2015 certification.

## 5 reasons to trust us



### Expertise

Our field experts propose you solutions adapted to your environment and specific needs.



### Innovation

By developing the products and the services of tomorrow, we offer you new perspectives or prospects.



### Performance

Our high added value solutions improve your performances and guarantee the final quality of the production.



### Commitment

Aware of your objectives, we commit ourselves to helping you to reach them.



### Reliability

Our organization which has been ISO 9001 certified since 1996, is the guarantee of your satisfaction.



ASSEMBLY TECHNOLOGY

As world class assembly technology player, we manufacture and market equipments and solutions for the assembly industry which contribute to the improvement of your manufacturing quality and productivity.

Our assembly, ergonomics and traceability solutions contribute to enhancing your productivity, controlling your process quality and meet the requirements of industry 4.0.

We offer products designed to last and high value-added services by relying on our teams know-how and expertise : design, production, installation, start-up, training and maintenance. We support you locally thanks to our worldwide presence through our subsidiaries and our specialized distribution network.



Contact us

@ international@dogas.com

+33 1 30 66 41 41

www.dogasassembly.com

# SUMMARY

## AIR VACUUM SYSTEMS

Pages

- ▶ **4**      MAINS FEATURES
- ▶ **5**      VACUUM SYSTEM COMBINATIONS
- ▶ **6**      ACCESSORIES
- ▶ **8**      PRODUCT AND SERVICE REFERENCES
- ▶ **11**     AIR VACUUM SYSTEM INQUIRY
- ▶ **12**     SPECIAL APPLICATION CASE
- ▶ **13**     OUR SERVICES

# SCREWDRIVER ACCESSORY TO HOLD SCREWS

The assembly of non-magnetic screws or small screws, is tricky and also difficult when access to the tightening point is restricted.

- ▶ Allow the screw to be held in position by vacuum to free the operator's hand and speed up the assembly process.
- ▶ Ease the tightening process in spaceless location.
- ▶ Avoid unexpected fall of screws into the parts.

## MAINS FEATURES

### Air vacuum kit

The kit is an accessory to be mounted on the screwdriver extremity and including :

- ▶ x1 vacuum system suitable with the screwdriver model
- ▶ x1 customized tube
- ▶ x1 bit guiding ring

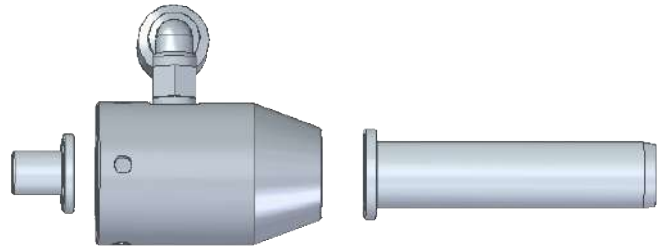

On the DELVO® screwdrivers, the vacuum system is integrated to the screwdriver, so you only need to order a tube.

### Tube

- ▶ Machined according to the screw head.
- ▶ Direct contact with the product
- ▶ The tube diameter must be greater than or equal to the screw head diameter +2 mm.
- ▶ Free tube length on the kit endpoint from 25 to 35 mm.

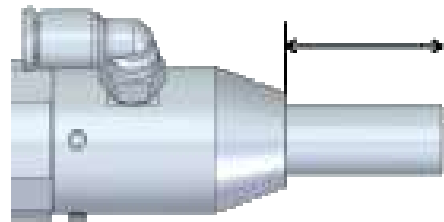

If one of the hereabove characteristics is not suitable with your application, please contact us for a special design and fulfill the questionnaire of page 11.











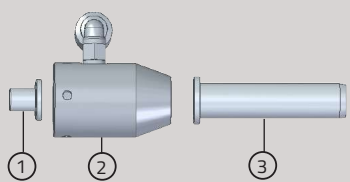

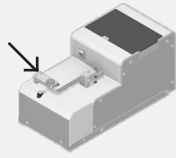
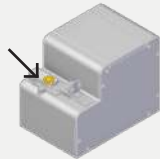







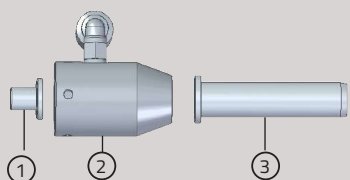

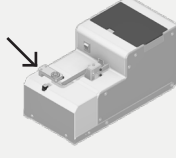
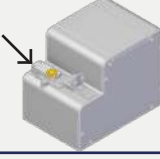





### Bit

- ▶ Customized according to your screw diameter and screwhead foot print.

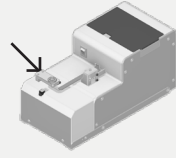
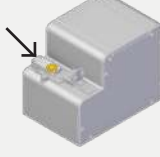
### Screwdriver

- ▶ To be used with trigger start or external start screwdrivers.

# VACUUM SYSTEM COMBINATIONS



		Optional accessories		
Assembly tool model	Vacuum system composition	Bit model to select according to the screw features	Vacuum generator	Support and guide for tube
<b>Torque and angle current control tool</b> Models : MD26 / MD32 / MDA26 / MDA32 	① Bit guiding ring ② Vacuum system ③ Customized tube 	PH / PZ bits LG 89 mm* 	Standard vacuum generator 	Support and guide for NJR or NSR screwfeeder  
		Precision bit PH / PZ LG 100 mm* 	High vacuum generator 	
		Bit for socket head (Hex int) screws LG 100 mm* 	DELVO® vacuum pump 	
		Torx bits LG 89 mm 		
<b>Torque and angle current control tool</b> Models : MD22 		Bit PH / PZ / TX LG 64 mm half moon 4 mm 		
<b>Shut-off brushless electric tool</b> Models : GX 30V / GX 40V 	① Bit guiding ring ② Vacuum system ③ Customized tube 	Bit PH / PZ LG 89 mm* 	Standard vacuum generator 	Support and guide for screwfeeder - NJR or NSR range  
		Precision bit PH / PZ LG 100 mm* 	High vacuum generator 	
		Bit for socket head (Hex int) screws LG 100 mm* 	DELVO® vacuum pump 	
		Bit for Torx LG 89 mm 		
<b>DELVO® electric screwdriver</b> Models : DLV 7325 CKE DLV 7335 CKE DLV 7321 BKE 	Tailor-made tube to be mounted directly at the end of the vacuum system integrated into the screwdriver. 	Bit PH / PZ LG (special on request)* 	Standard vacuum generator 	Support and guide for screwfeeder - NJR or NSR range  
	Precision bit PH / PZ LG (special on request)* 	High vacuum generator 		
	Bit for socket head (Hex int) screws LG (special on request)* 	DELVO® vacuum pump 		
	Bit for Torx LG (70 mm) 			

\* To be customized according to the screw features, sold in sets of 10 bits.

# ACCESSORIES

## Vacuum generator

### Venturi vacuum generator

	Standard vacuum generator	High vacuum generator
		
Mounting position	Indifferent	Indifferent
Design	T shape	Straight shape
Rated operation pressure	6 bar	6 bar
Operating pressure at max. suction flow rate	6,3 bar	5 bar
Operating pressure at max. vacuum	6 bar	5,8 bar
Max. vacuum	86 %	86 %
Max suction capacity	6,1 l/min	28 l/min
Pressure build-up time at nominal working pressure	4,7 s	0,96 s
Operating fluid	Compressed air according ISO8573-1:2010 [7:4:4]	Compressed air according ISO8573-1:2010 [7:4:4]
Control and pilot fluid	Operation with lubrication not possible	Operation with lubrication not possible
Corrosion resistance class KBK	1 - low corrosion effects	1 - low corrosion effects
Fluid temperature	0 to 60°C	0 to 60°C
Ambiant temperature	0 to 60°C	0 to 60 °C
Max tightening torque	0,5 Nm	-
Weight	22 g	23 g
Fixing method	Through hole	In line on hose
Compressed air supply connection	G1/8	Push-in connector 6 mm
Exhaust connection	G1/8	Unchannelled
Vacuum connection	G1/8	Push-in connector 6 mm

## Vacuum pump

### DELVO® vacuum pump



Supply voltage	230 V AC 50/60 Hz
Power	30 W
Vacuum supplied	-21,3 Kpa
Flow rate	24 l/min.
Weight	3,8 kg

## Sleeve support and guide

For hidden time distribution of the screw we recommend the use of our screwfeeders NJR / NSR range, and thus increase your productivity.

In order to ease the centering of the tube on the screw located in the rail of the screwfeeder, we recommend you to equip the screwfeeder with a centering guide.

The inside diameter of the guide must correspond to the diameter of the tube.

### NSR screwfeeder

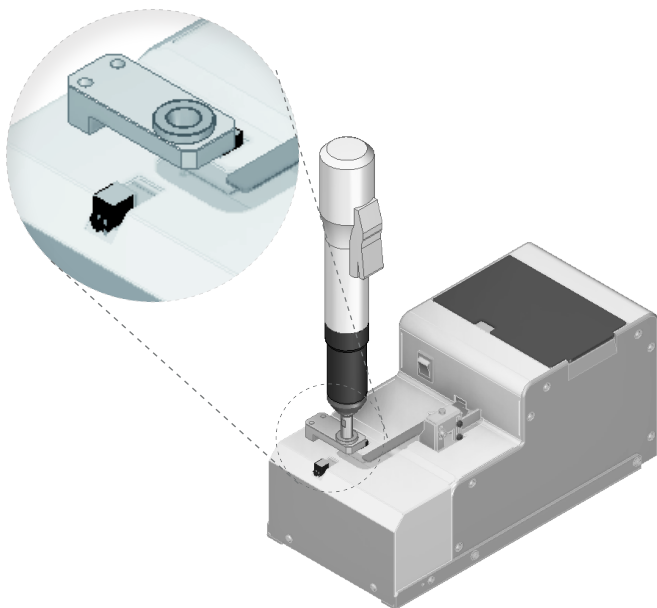

### NJR screwfeeder

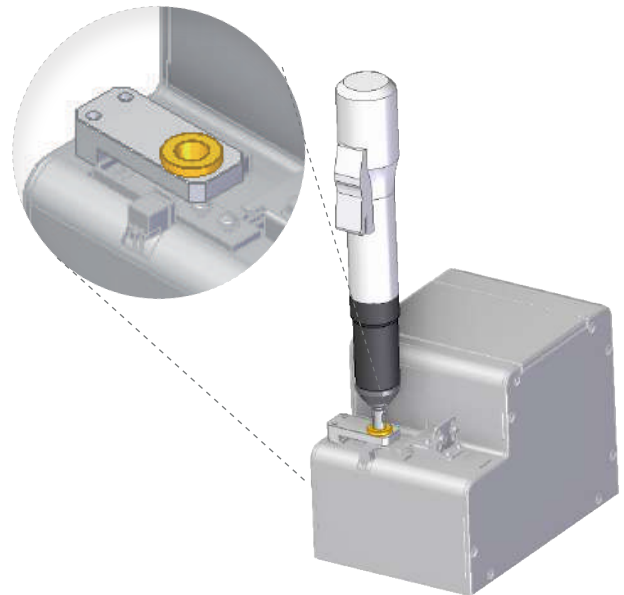

The mounting of the guide and support on the distributor can be carried out by our technical services (service to be ordered).

# PRODUCT AND SERVICE REFERENCES

## Complete vacuum kits

(include the vacuum system, customized tube and the bit guiding ring)\* :

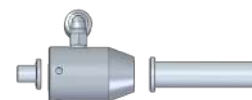

Model	Code
Complete vacuum kit for GX30V with torque adjustment ring access	4-1525009
Complete vacuum kit for GX30V without torque adjustment ring access	4-1525012
Complete vacuum kit for GX40V	4-1525014
Complete vacuum kit for MD26-A and MDA26-A / MDT26-A / MDTA26-A**	4-1525015
Complete vacuum kit for MD32-A and MDA32-A / MDT32-A / MDTA32-A**	4-1525017
Complete vacuum kit for MD22-E and MDA22-E**	4-1500045

\* Cost of study and realization of customized tube and guiding ring are included.

\*\* Vacuum systems can be installed on MDA and MDTA spindles only if they are not equipped with telescopic cushion.

## Steel tube for vacuum system integrated to the DELVO screwdrivers DLV 7325/35 CKE & 7321 BKE :



Model	Code
Steel tube for DELVO® vacuum system (cost of study and realization included)	4-1525021

## Steel spare tubes for vacuum system\* :



Model	Code
Steel spare tube for DELVO® vacuum system (according to existing drawing)	4-3006014
Steel spare tube for GX30V vacuum system (according to existing drawing)	4-1525022
Steel spare tube for GX40V vacuum system (according to existing drawing)	4-1525023
Steel spare tube for MD26-A and MDA26-A / MDT26-A / MDTA26-A** vacuum system (according to existing drawing)	4-1525024
Steel spare tube for MD32-A and MDA32-A / MDT32-A / MDTA32-A** vacuum system (according to existing drawing)	4-1525025
Steel spare tube for MD22-E and MDA22-E** vacuum system (according to existing drawing)	4-1500053

\* Codes to be used only for ordering a tube same as one already delivered (please indicate the existing drawing number on your order).

\*\* Vacuum systems can be installed on MDA and MDTA spindles only if they are not equipped with telescopic cushion.

## Bits

(footprint to be specified when ordering)



Model	Code
Bit PH / PZ LG 89 mm for vacuum kit (pack of 10 bits)	4-1525026
Precision bit PH / PZ LG 100 mm for vacuum kit (pack of 10 bits)	4-1525027
Bit for socket head (Hex int) screws LG 100 mm for vacuum kit (pack of 10 bits)	4-1525028
Bit PH / PZ / TX LG 64 mm for vacuum kit MD 22 (pack of 10 bits)	See doc.60292
Bit for Torx LG 70 mm exclusively for Delvo screwdriver	See doc.60292
Bit PH / PZ / socket head (Hex int) exclusively for Delvo screwdriver	On request



## Vacuum systems (sold separately\*)



Model	Code
Vacuum system GA / GX30V	4-1052500
Vacuum system GX30V V2 with torque ring access	4-1084103
Vacuum system GX30V V2 without torque ring access	4-1084104
Vacuum system GX150/GX220 ESD-G	4-1084100
Vacuum system GX450 ESD-G	4-1084101
Vacuum system GXA ESD-G 40V	4-1084102
Vacuum system GXA ESD-G 30V	4-1000039
Vacuum system GX MICRO	4-1052501
Vacuum system GX150/GX220-H	4-1027496
Vacuum system GX450-H	4-1027497
Vacuum system GXA-H 40V	4-1027498
Vacuum system HDA	4-1042228
Vacuum system HD150-G	4-1052508
Vacuum system M20 Hex1/4 MD26xx-A, MD3201-A, MD3202-A MDA26xx-A, MDA3201-A, MDA3202-A** MDT2604-A to MDT2616-A	4-1050589
Vacuum system M23 Hex 1/4 MD3204-A to MD3216-A MDA3204-A to MDA3216-A** MDT3204-A, MDT3206-A/L to MDT3216-AL MDTA3204-A to MDTA3216-A**	4-1050590
Vacuum system M20 4 mm half moon MD2601-E/MD2602-E MDA2601-E/MDA2602-E**	4-1050591
Vacuum system M16 4 mm half moon MD2201, MD2203 MDA2201, MDA2203**	4-1050752

\* Delivered without tube and bit guiding ring (please use those codes only if you want to build your own vacuum tubes and bit guiding rings).

\*\* Vacuum systems can be installed on MDA and MDTA spindles only if they are not equipped with telescopic cushion.

## Vacuum generator



Model	Code
Standard vacuum generator	4-3020305
High vacuum generator	4-3000032
Vacuum pump DELVO® DLP2570	4-3004101

## Support and guide for tube on feeder NJR / NSR

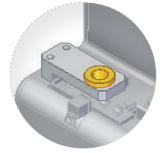
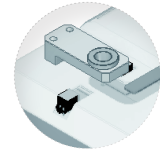



Model	Code
Support and guide for tube DELVO® / GX30V	4-1525007
Support and guide for tube GX40V	4-1525029
Support and guide for tube MD26	4-1525030
Support and guide for tube MD32	4-1525031
Support and guide for tube MD22	4-1500046

## Mounting service



Model	Code
Support and guide mounting on NJR/NSR (1 hour) "	4-1525011

# AIR VACUUM SYSTEM INQUIRY

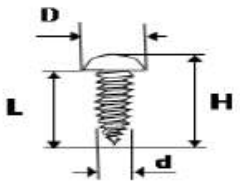
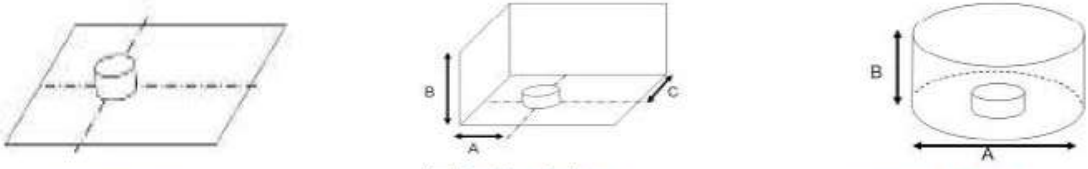
	<b>AIR VACUUM SYSTEM &amp; SLEEVES</b> <b>INQUIRY</b>												
Customer number													
Company :	Quote :												
Application Data													
Direct contact with the product possible	Torque Nm												
Tightening through a guiding mask	%												
To be specified in complementary informations													
Screw specification													
 													
Please supply screw sample + Drawing													
	<table border="1" style="margin-left: auto; margin-right: auto;"> <tr><td>D</td><td>#NA</td></tr> <tr><td>L</td><td>#NA</td></tr> <tr><td>H</td><td>#NA</td></tr> <tr><td>d</td><td>#NA</td></tr> </table>	D	#NA	L	#NA	H	#NA	d	#NA				
D	#NA												
L	#NA												
H	#NA												
d	#NA												
Part and screw surrounding area													
													
<input type="checkbox"/> No restriction <input type="checkbox"/> 2 sides built up <input type="checkbox"/> Screw in a hole													
A	B												
C													
Screwdriver and screwfeeder references													
<table border="1" style="width: 100%; border-collapse: collapse;"> <thead> <tr> <th colspan="2" style="text-align: left;">Screwdriver</th> <th colspan="2" style="text-align: left;">screwfeeder</th> </tr> <tr> <th style="width: 25%;">Code</th> <th style="width: 75%;">Model</th> <th style="width: 25%;">Code</th> <th style="width: 75%;">Model</th> </tr> </thead> <tbody> <tr> <td style="height: 20px;"></td> <td></td> <td></td> <td></td> </tr> </tbody> </table>		Screwdriver		screwfeeder		Code	Model	Code	Model				
Screwdriver		screwfeeder											
Code	Model	Code	Model										
<input type="checkbox"/> Sleeve support and guide on the screwfeeder													
Complementary informations													

## SPECIAL APPLICATION CASE

---

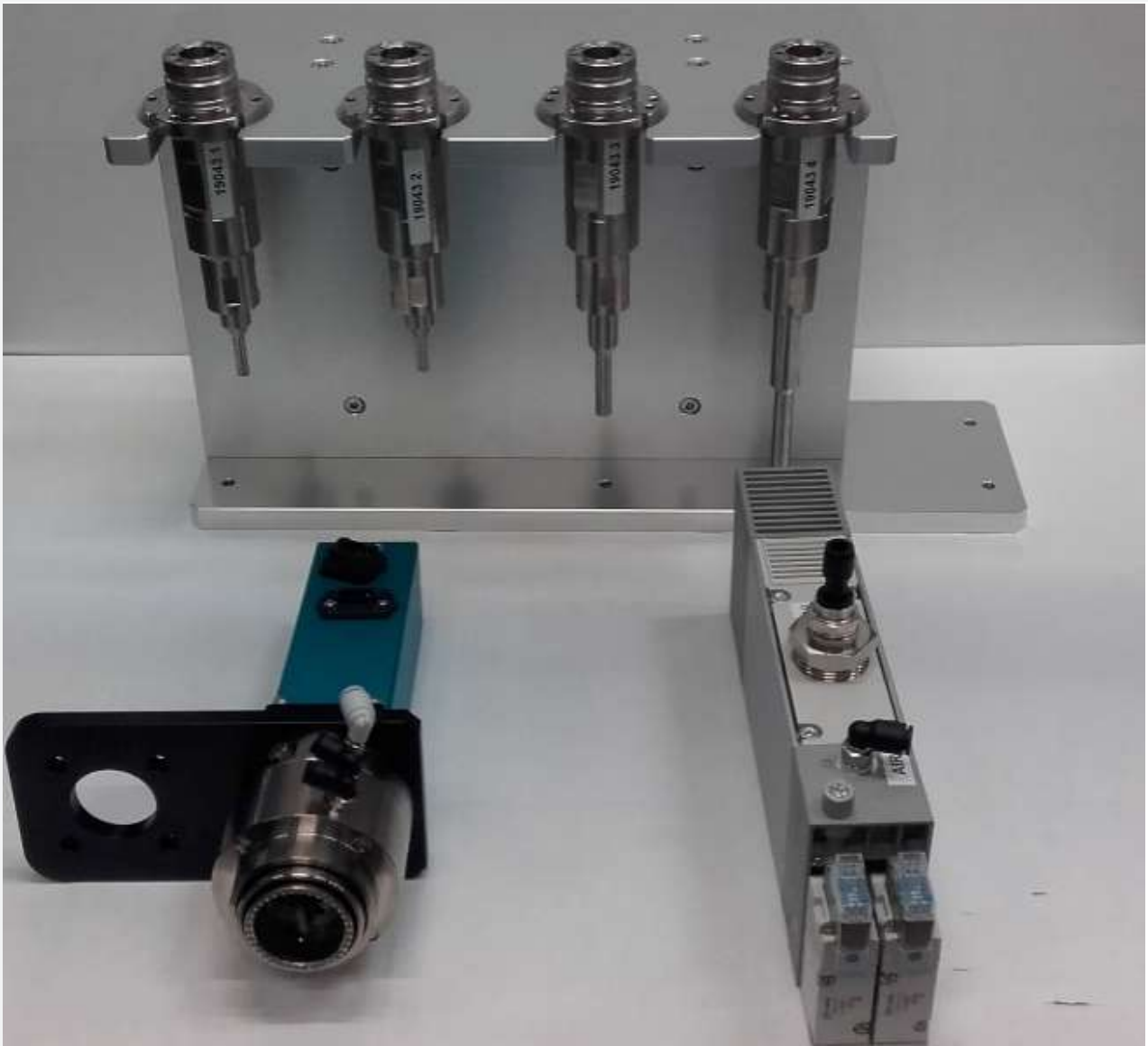

### QUICK CHANGE OF VACUUM SYSTEM

Automation of the tightening of several screws of different types on a robotic installation where the distribution of the screws is ensured by a rail distributor with a screw intake by aspiration.

Scan the QR code to see the details of the application



## YOU NEED A TAILOR-MADE SOLUTION?

---

Please contact-us: [international@doga.fr](mailto:international@doga.fr)

# OUR SERVICES

If DOGA put at your disposal reliable, accurate and user friendly tightening solutions it is our duty to advise you the right solution for your application.

Our Product Manager and Support engineering team are there to analyse your manufacturing process and share with you our innovating solutions to improve your assembly process. Thanks to our technical integration service CELPRO we provide you with Turn-key solutions from the design to the commissioning.



## TURNKEY SOLUTIONS

Around the various options of our product ranges, we offer you solutions adapted to your needs :

- ▶ Custom design
- ▶ Adaptation of existing models
- ▶ Integration of automation system



## TECHNICAL ASSISTANCE

To ensure optimized performance and durability of our tools we put at your disposal :

- ▶ Installation and start-up
- ▶ Maintenance agreement
- ▶ On-site maintenance
- ▶ Maintenance in our workshop



## TRAINING

Doga offers specialized training courses around its trades :

- ▶ Theoretical
- ▶ Technical & practical
- ▶ Audit & consulting

# ASSOCIATED PRODUCTS



## Torque and angle control tools - MD / MDA series

Precise, robust and ergonomic, these screwdrivers meet your requirements for throughput, repeatability and traceability.



Consult the commercial documentation DOC.60303



## Shut-off brushless electric screwdrivers - GX serie

Designed on the highest criteria of precision, ergonomics and robustness, these screwdrivers allow you to optimize your low-torque automated assemblies.



Consult the commercial documentation DOC.60207



## DELVO® electric screwdrivers

These basic voltage and direct current screwdrivers are perfectly suited to applications requiring a vacuum grip as the vacuum system is integrated into the screwdriver.



Consult the commercial documentation DOC.60020



## Screw feeding

Reduce your cycle times with our interchangeable rail automatic screw feeding systems (NJR / NSR models).



Consult the commercial documentation DOC.40051



Find all our ASSEMBLY TECHNOLOGY products on our website by scanning this QR code



---

**DOGA**<sup>®</sup> | ASSEMBLY TECHNOLOGY

📧 international@doga.fr

☎ +33 1 30 66 41 41

📍 8, avenue Gutenberg - CS 50510  
78317 Maurepas Cedex - FRANCE

© DOGA | DOC.60355.11/22

We constantly strive to improve our products. As a result, the dimensions and indications in this document may not always correspond to the latest production. By explicit agreement, our sales are subject to a reservation of title (the provisions of the French 05/12/1980 Act are therefore fully applicable).

[www.dogasassembly.com](http://www.dogasassembly.com)